

CHANGE ORIENTATION TO LANDSCAPE BEFORE PRINTING.

CONTINUE

PLEASANT COLUMBUS GROVE CORPORATION 00470		real property record	PUTNAM COUNTY, OHIO				47-069110.0000	res
7/02/21		11:58:08	ROBERT L. BENROTH, AUDITOR				02-01-039	
2017 VAUGHN PAUL V SR & ETHEL J	6/18/92	sale	eff rate:	41.93	41.95	41.57	42.29	a/r
2018 VAUGHN PAUL V SR & ETHEL J	6/18/92		tax year	2017	2018	2019	2018	2018
2019 VAUGHN PAUL V SR & ETHEL J	6/18/92 lot : 272		prop cls	510	510	510	510	510
2018 VAUGHN PAUL V	10/23/19 IL 00272 & 1/2 VAC ALLEY		acres					
	301 E SYCAMORE ST COLUMBUS GROVE OH 45830		land100%	7910	7910	7910	7910	7920
			bldg100%	46510	46510	46510	55170	55180
			totl100%	54420t	54420t	54420t	63080t	63100t
2019			tax value:					
			land 35%	2770	2770	2770	2770	2770
			bldg 35%	16280	16280	16280	19310	19310
			totl 35%	19050t	19050t	19050t	22080t	22080t
			hmstd35%					
			2.5% rb					
			hmstd rb					
			net tax	725.52	727.00	720.60	849.50	
			sp-asmnt	15.46	15.46	413.30	15.46	

SHB+.cons.type.fc.sq-ft value

2	F	M	432	a	*MAIN
	EFP	P	72	800	b PORCH
1	B	F	A	720	d ADDTN
	F	G	216	2300	e GARAGE
45	F	O	240	650	f S KITCHEN
	EFP	P	132	2300	g PORCH

SHINGLE

17RV ADD C/A,SHDS,CHG OFF-EFP

ADV06 ADV18 ADV20

sale#	#p	mm	dd	yy	to/remarks	type/invalid?	sale\$	co:land	co:bldg
103		2/19/21			VAUGHN SAMANTHA	QCD		7910	55170
515		10/23/19			VAUGHN PAUL V	CER		7910	46510

year	land	bldg	total	net tax
2018	2770	16280	19050	727.00

project

fac's	ben	acr.	charged
373-00000	OTTAWA RIVER STREA		2016/M
17-00000	C-G MOWING/TRIM/WE		2020/A

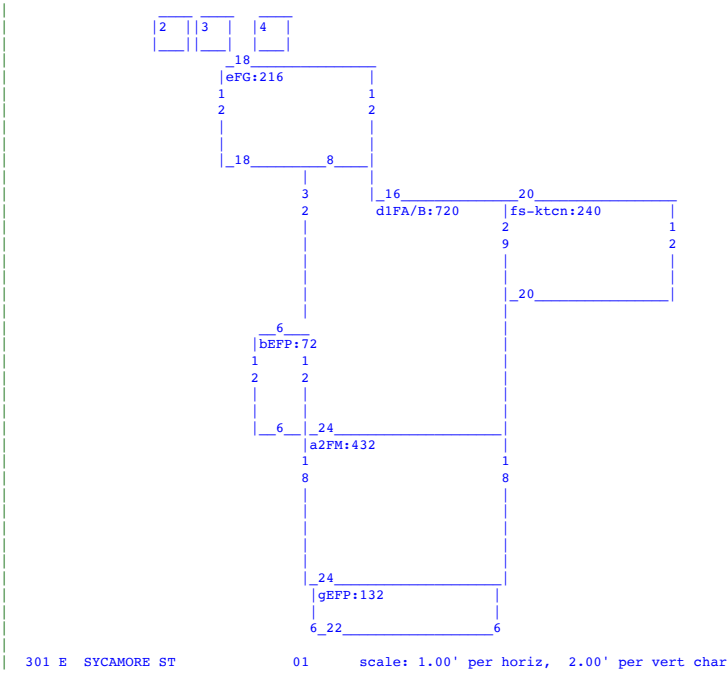

occupancy	1	SINGLE FAM	*DWELLING COMPUTATIONS		DixHt	unit	blt/Renov	replace	phy	fn	true
story hgt	2		sq-ft	value			cond	value	dpr	dpr	value
floor lvl	main	FRAME	1152	86400	1 DWELLING	2 B F	C	OLD P	118750	65	51950
	full upr	FRAME	432	21800	2 GARAGE	1 F	C	OLD POM	5200	65	2280
	basement		180	1900	3 SHED	*NV	C	1970A			
	subtotal			110100	4 SHED	10X24	C	1990A	1560	39	950

acres/	efectv	dpth	actual	efectv	extnd	influence	true
frontge	frontge	dpth	fctr	rate	value	factor(s)	value
front lot	60.00	132	.94	140	132	7920	7920

301 E SYCAMORE ST 01 scale: 1.00' per horiz, 2.00' per vert char

call back: - - - - sign: date: 10/28/04 lister:KK -----47-069110.0000-v020614