

Parcel ID: F16-0001-0005-0-0002-00

Tax Year: 2016

Card: 1 of 2

Owner: ARNOVITZ ENTERPRISES
 Mailing Name/Address:
 ARNOVITZ ENTERPRISES
 1440 PASSPORT LN
 DAYTON OH 45414-5914
 Tax District: F16 - MIAMI TP YSEVSD

Description: 8-4-25 NW PT EASE .19A
 HUSTON RD AT 106.9464AC
 131 E DAYTON Y S RD
 Property Address: 131 E DAYTON YELLOW SPRINGS RD
 Class: A - CASH GRAIN OR GENERAL FARM
 Map/Routing: 0005.00 005.00
 Neighborhood: 00122.001
 Parcel Tieback:



F16000100050000200 02/15/2012

LAND DATA	Effective	Square	Value			
Desc	Type	Frontage	Depth	Footage	Acres	Value
Homesite	ACREAGE				2.0000	\$88,000.00
Tillable	ACREAGE				69.5150	\$389,280.00
Right of Way	ACREAGE				1.4610	\$0.00
Woodland	ACREAGE				2.1500	\$6,450.00
Pasture	ACREAGE				31.8200	\$133,640.00

SALES DATA	Type	Amount	Source
Sale Date			

DWELLING DATA					
Style	OLD STYLE TWO STORY	Total Rooms	7	Masonry Trim Area	
Story Hgt	2.00	Bedrooms	4	Unfin Area	
Construct	ALUMINUM/VINYL	Family Rms	0	Rec Room Area	
Year Blt	1900 Remod 1983	Full Baths	1	Fin Bsmt Area	
SFLA	1995	Half Baths	0	WBFP Stacks	Open
GFLA	800	Add'l Fixt	2	Bsmt Garage # Cars	
Basement	PART	Total Fixt	5	Misc Desc	
Heating	CENTRAL	Bath Remod	NO	Misc Desc	
Heat Fuel	GAS	Kitch Remod	NO	Condo Level	
Attic	NONE			Condo Type	
Int vs Ext	2				

VALUES	Land Value	Bldg Value	Total Value	Value Date
Appraised	\$617,370.00	\$128,050.00	\$745,420.00	12/28/2016
Assessed (35%)	\$216,080.00	\$44,820.00	\$260,900.00	

TAXES	Delinquent	1st Half	2nd Half	Total
Real:	\$0.00	\$4,311.70	\$4,311.70	\$8,623.40
Special	\$0.00	\$0.00	\$0.00	\$0.00
Total:	\$0.00	\$4,311.70	\$4,311.70	\$8,623.40
Total Tax:				\$8,623.40
Amount Due:				\$8,623.40

PROPERTY FACTORS			
Topography	Utilities	Street/Road	Traffic
ABOVE STREET	WELL SEPTIC	PAVED	LIGHT

ADDITION DATA					
#	Lower	First	Second	Third	Area
A0		MAIN BUILDING			800
A1		ENCL FRAME PORCH			176
A2	50	FRAME	ATTIC-FINISHED		282
A3		OPEN FRAME PORCH			75
A4		WOOD DECKS			24

OTHER BUILDING & YARD ITEMS					
Description	Yr Blt	Area	Rate	Units	Value
DETACHED CB MILK HOUSE	1900	120	54.5000	1.00	\$650.00
BANK BARN	1900	2800	26.6000	1.00	\$17,880.00

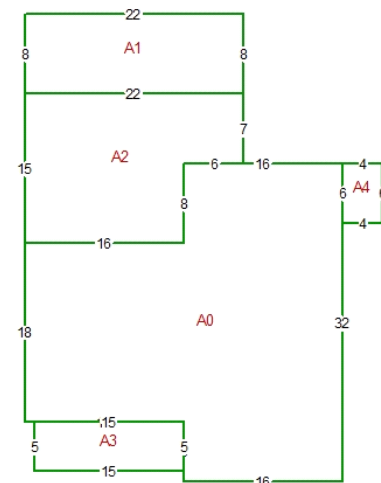

Parcel ID: F16-0001-0005-0-0002-00

Tax Year: 2016

Card: 2 of 2

Owner: ARNOVITZ ENTERPRISES	Description: 8-4-25 NW PT EASE .19A
Mailing Name/Address: ARNOVITZ ENTERPRISES	HUSTON RD AT 106.9464AC 131 E DAYTON Y S RD
1440 PASSPORT LN DAYTON OH 45414-5914	Property Address: 131 E DAYTON YELLOW SPRINGS RD
Tax District: F16 - MIAMI TP YSEVSD	Class: A - CASH GRAIN OR GENERAL FARM
	Map/Routing: 0005.00 005.00
	Neighborhood: 00122.001
	Parcel Tieback:

LAND DATA						
Desc	Type	Effective Frontage	Depth	Square Footage	Acres	Value

SALES DATA			
Sale Date	Type	Amount	Source

DWELLING DATA				
Style	CONVERSION	Total Rooms	4	Masonry Trim Area
Story Hgt	1.00	Bedrooms	1	Unfin Area
Construct	ALUMINUM/VINYL	Family Rms		Rec Room Area
Year Blt	1995 Remod	Full Baths	1	Fin Bsmt Area
SFLA	1008	Half Baths	0	WBFP Stacks
GFLA	720	Add'l Fixt	2	Bsmt Garage # Cars
Basement	NONE	Total Fixt	5	Misc Desc
Heating	CENTRAL AIR CONDITION	Bath Remod	NO	Misc Desc
Heat Fuel	GAS	Kitch Remod	NO	Condo Level
Attic	FULLY FINISHED			Condo Type
Int vs Ext	2			

VALUES				
	Land Value	Bldg Value	Total Value	Value Date
Appraised				
Assessed (35%)				

TAXES				
	Delinquent	1st Half	2nd Half	Total

PROPERTY FACTORS			
Topography	Utilities	Street/Road	Traffic
ABOVE STREET	WELL SEPTIC	PAVED	LIGHT

ADDITION DATA					
#	Lower	First	Second	Third	Area
A0		MAIN BUILDING			720
A1		FRAME GARAGE			1088
A2		CONC/BRICK PATIO			304

OTHER BUILDING & YARD ITEMS					
Description	Yr Blt	Area	Rate	Units	Value